

MOOG

**760 Series
Servovalves
ISO 10372 Size 04**

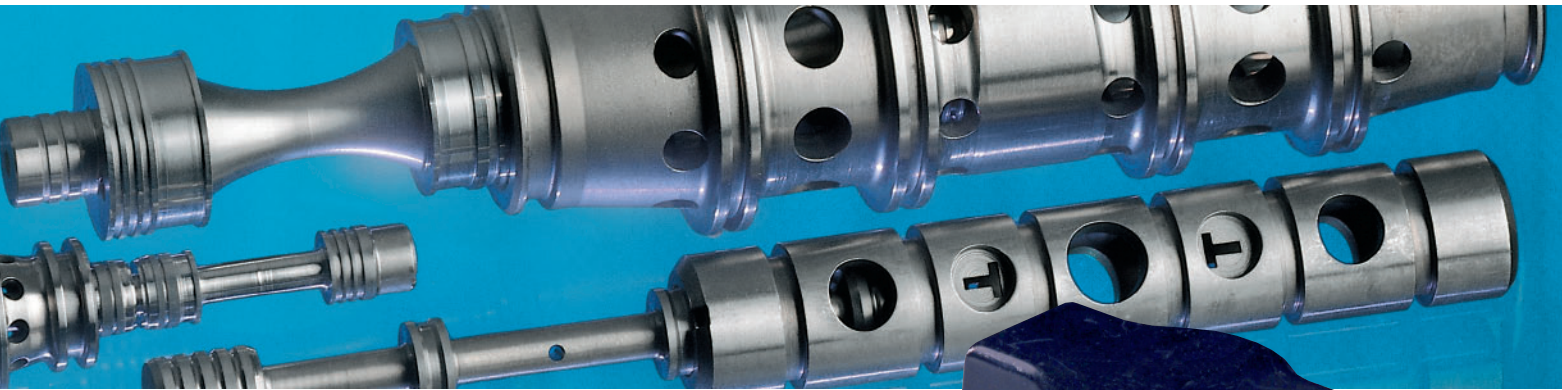

760 SERIES TWO STAGE SERVOVALVES

760 SERIES SERVOVALVES

The 760 Series flow control servovalves are throttle valves for 3-, and preferably 4-way applications. They are a high performance, two-stage design that covers the range of rated flows from 1 to 15 gpm at 1000 psi valve drop. The output stage is a closed center, four-way, sliding spool. The pilot stage is a symmetrical double-nozzle and flapper, driven by a double air gap, dry torque motor. Mechanical feedback of spool position is provided by a

cantilever spring. The valve design is simple and rugged for dependable, long life operation.

These valves are suitable for electrohydraulic position, speed, pressure or force control systems with high dynamic response requirements.

Principle of operation

An electrical command signal (flow rate set point) is applied to the torque motor coils and creates a magnetic force which acts on the ends of the pilot stage armature. This causes a

deflection of armature/flapper assembly within the flexure tube. Deflection of the flapper restricts fluid flow through one nozzle which is carried through to one spool end, displacing the spool.

Movement of the spool opens the supply pressure port (P) to one control port while simultaneously opening the tank port (T) to the other control port. The spool motion also applies a force to the cantilever spring, creating a restoring torque on the armature/flapper assembly.

Once the restoring torque becomes equal to the torque from the magnetic forces, the armature/flapper assembly moves back to the neutral position, and the spool is held open in a state of equilibrium until the command signal changes to a new level.

In summary, the spool position is proportional to the input current and, with constant pressure drop across the valve, flow to the load is proportional to the spool position.

VALVE FEATURES

- > 2-stage design with dry torque motor
- > Low friction double nozzle pilot stage
- > High spool control forces
- > High dynamics
- > Rugged, long-life design
- > High resolution, low hysteresis
- > Completely set-up at the factory
- > Optional fifth port for separate pilot supply
- > Intrinsically safe or flameproof valve versions are available

The actual flow is dependent upon electrical command signal and valve pressure drop. The flow for a given valve pressure drop can be calculated using the square root function for sharp edge orifices:

$$Q = Q_N \sqrt{\frac{\Delta p}{\Delta p_N}}$$

- Q [gpm] = calculated flow
- Q_N [gpm] = rated flow
- Δp [psi] = actual valve pressure drop
- Δp_N [psi] = rated valve pressure drop



This catalog is for users with technical knowledge. To ensure that all necessary characteristics for function and safety of the

system are given, the user has to check the suitability of the products described here. In case of doubt, please contact Moog Inc.



Intrinsically safe valve versions are available for use in hazardous locations. Specific models are certified to FM, ATEX, CSA, and TIIS standards. Contact the factory for details.

**760 SERIES
GENERAL TECHNICAL DATA**

Operating Pressure*

ports P, X, A and B up to 3,000 psi
port T up to 3,000 psi

Temperature Range

Fluid -20°F to 275°F
Ambient -20°F to 275°F

Seal Material

Viton**

Operating Fluid

Compatible with common hydraulic fluids, other fluids on request.

Recommended viscosity 60 – 450 SUS @ 100°F

System Filtration: High pressure filter (without bypass, but with dirt alarm) mounted in the main flow and, if possible, directly upstream of the valve. Refer to Moog filtration catalog for recommended filtration scheme.

Class of Cleanliness: The cleanliness of the hydraulic fluid greatly effects the performance (spool positioning, high resolution) and wear (metering edges, pressure gain, leakage) of the servovalve.

Recommended Cleanliness Class

For normal operation ISO 4406 < 14/11
For longer life ISO 4406 < 13/10

Filter Rating recommended

For normal operation $\beta_{10} \geq 75$ (10 μ m absolute)
For longer life $\beta_5 \geq 75$ (5 μ m absolute)

Installation Operations

Any position, fixed or movable.
30 g, 3 axes

Vibration

Weight

1.13 lb (1.91 lb for steel body)

Degree of Protection

EN60529P: class IP65, with mating connector mounted.
Delivered with an oil sealed shipping plate.

Shipping Plate

* Maximum special order is 8,000 psi

** Other seal material upon request

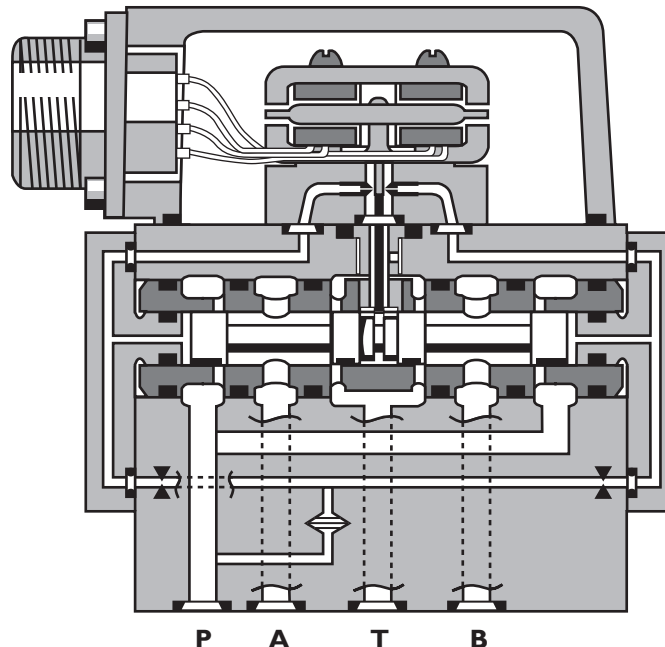
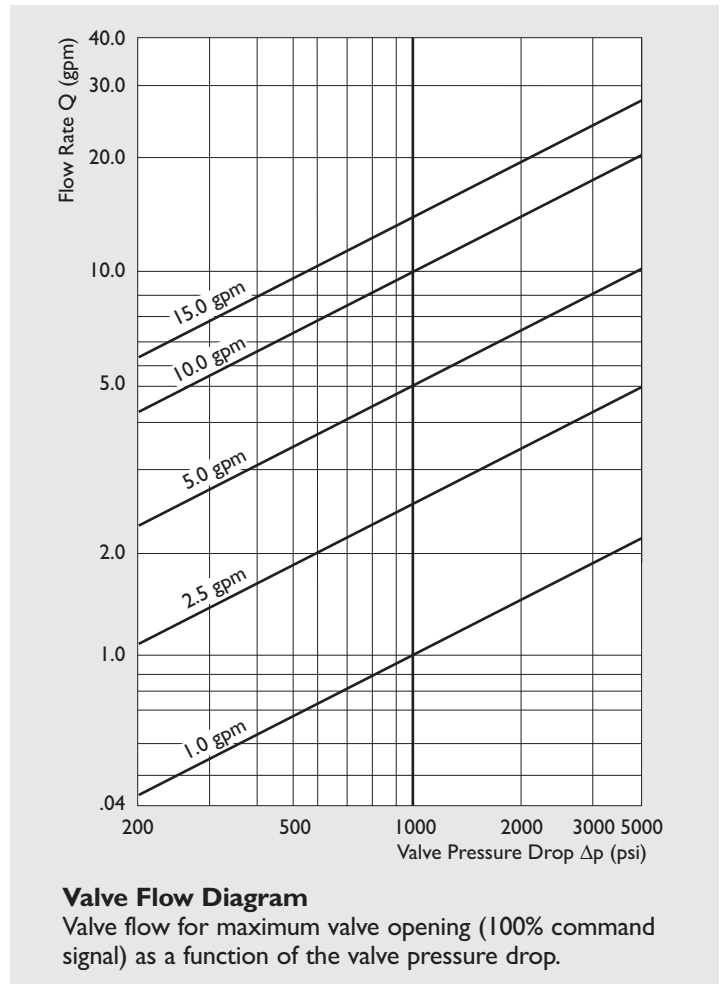

**760 SERIES
TECHNICAL DATA**

Model...Type
Mounting Pattern
Valve Body Version

760-.....

ISO 10372 - 04 - 04 - 0 - 92

4-way

2-stage with spool-bushing assembly

Nozzle/Flapper, Highflow

Pilot Stage
Pilot Connection Optional, Internal or External

X

Rated Flow ($\pm 10\%$) at $\Delta p_N = 1,000$ psi

Standard	[gpm]	1.0	2.5	5.0	10.0	15.0
High Response	[gpm]	1.0	2.5	5.0	10.0	15.0

Response Time @ 3000 psi

Standard	[ms]	6	6	6	10	16
High Response	[ms]	4	4	4	7	13

Threshold*	[%]	0.5
Hysteresis*	[%]	3.0
Null Shift	at $\Delta T = 100^\circ F$ [%]	< 2.0
Null Leakage Flow*	max. [gpm]	0.40 to 0.61
Pilot Leakage Flow*	max. [gpm]	0.26
Spool Drive Area	Standard [in ²]	.076
	High Response [in ²]	.053
	Super High Response [in ²]	.025

* Measured at 3,000 psi pilot or operating pressure

Typical Characteristic Curves with $\pm 40\%$ and $\pm 100\%$ input signal, measured at 3,000 psi pilot or operating pressure.

Standard Valves

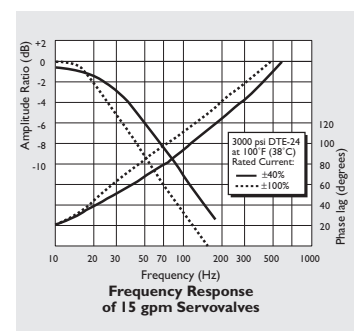
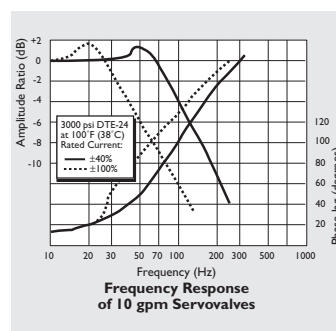
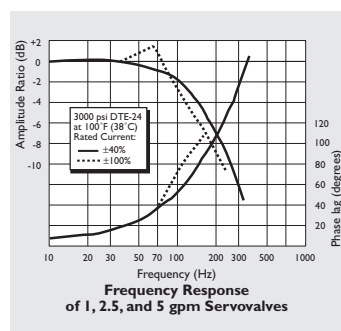

High and Super High Response Valves

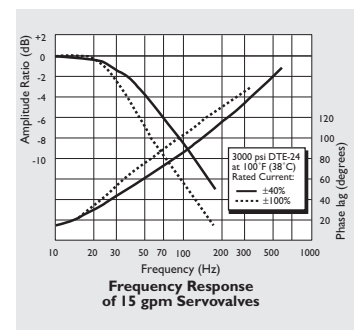
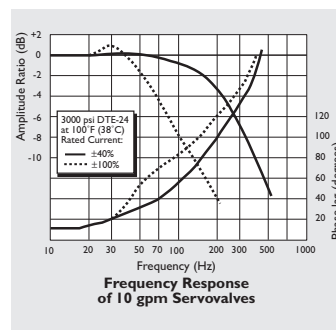
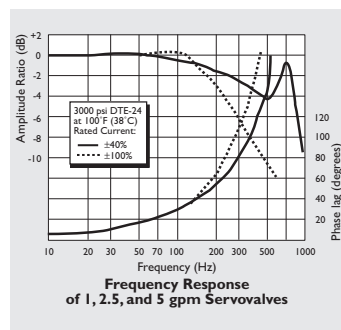

760 SERIES ELECTRICAL CONNECTIONS

Rated current and coil resistance

A variety of coils are available for 760 Series Servovalves, which offer a wide choice of rated current. See Table I.

Coil connections

A four-pin electrical connector (that mates with an MS3106/14S/2S) is standard. All four torque motor leads are available at the connector so external connections can be made for series, parallel, or differential operation.

760 Series Servovalves can be supplied on special order with other connectors or a pigtail.

Servoamplifier

The servovalve responds to input current, so a servoamplifier that has high internal impedance (as obtained with current feedback) should be used. This will reduce the effects of coil inductance and will minimize changes due to coil resistance variations.

ELECTRICAL CONNECTIONS

(Examples with typical 760 series coils)

Connector: MIL-C-5015/14S-2S

Coil Resistance	[Ω]	100
Rated Current	[mA]	± 15
Inductance	[H]	0.59
Electrical Power	[W]	.023
Connectors for Valve Opening		A and C (+) P \blacktriangleright B, A \blacktriangleright T B and D (-)

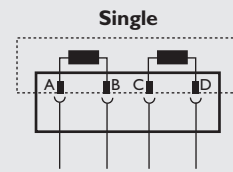
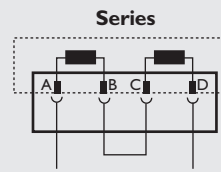
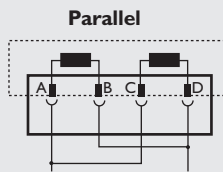

Coil Resistance	400	200
Rated Current	± 7.5	± 15
Inductance	2.20	.72
Electrical Power	.023	.045
Connectors for Valve Opening	A (+), D (-) B and C connected	A (+), B (-) or C (+), D (-)

Note: Before applying electrical signals the pilot stage has to be pressurized.

TABLE I

Nominal Resistance Per Coil at 77°F (25°C) Ω	Recommended Rated Current—mA		Approximate Coil Inductance*—Henrys		
	Parallel, Differential or Single Coil Operation	Series Coils	Single Coils	Series Coils	Parallel Coils
80	± 40	± 20	0.22	0.66	0.18
200	± 15	± 7.5	0.72	2.20	0.59
1000	± 8	± 4	3.20	9.70	2.60

* Measured at 50 Hz

760 SERIES ORDERING INFORMATION SPARE PARTS AND ACCESSORIES

Model Number

760

Type Designation

.

Optional Feature	
	Series specification
K	Intrinsically safe
N	Flameproof

Model Designation	
	Assigned at the factory

Factory Identification (Revision Level)	

Valve Version	
S	Standard response
H	High response
V	Super high response

Rated Flow		
	Q _v [gpm] at Δp _N = 1,000 psi	
	Standard	High Response
04	1	1
10	2.5	2.5
19	5.0	5.0
38	10.0	10.0
57	15.0	15.0

Maximum Operating Pressure p _p and Body Material	
F	3,000 psi aluminum
K	5,000 psi steel
Q	8,000 psi steel

Main Spool Type	
O	4-way / axis cut / linear
A	4-way / < +/-3% overlap - critical lap / linear
D	4-way / +/-10% overlap / linear
M	4-way / axis cut p _c > 80% of p _p / linear

Signals for 100% Spool Stroke	
4	±4 mA series
H	±7.5 mA series
L	±20 mA series
N	±30 mA series
Z	±100 mA series
Y	Special signal (see spec. sheet)

Valve Connector	
A	4-G (CA 02 COM) connector C1 (A) – side (RH)
B	4-G (CA 02 COM) connector C2 (B) – side (LH)
P	4-G (CA 02 COM) connector P – side
T	4-G (CA 02 COM) connector R (T) – side

Seal Material	
V	Fluorocarbon
N	NBR
	Others on request

Pilot Connections and Pressure		
	Pressure [psi]	Supply
A	250 to 3,000	internal
C	250 to 3,000	external
J	250 to 5,000	internal
L	250 to 5,000	external

Spool Position without Electrical Signal	
M	Mid position

Pilot Stage	
F	Standard dynamics
G	Improved dynamics

Preferred configurations highlighted.
All combinations may not be available.
Options may increase price and delivery.
Technical changes are reserved.

SPARE PARTS AND ACCESSORIES

O-Rings (included in delivery), for P,T,A and B	FPM 85 Shore ID 0.426 x 0.070	42082-022
for X	ID 0.364 x 0.070	42082-013
Mating Connector, waterproof IP 65 (not included in delivery)	P/N 49054FI4S2S (MS3106FI4S2S)	
Flushing Block	P/N 55124	

Mounting Bolts (not included in delivery) 5/16 - 18 NC x 1-3/4 long (4 pieces)	P/N A31324-228B
Replaceable Filter	P/N A01713-1
Field Replaceable Filter Kit	B52555RK4K1

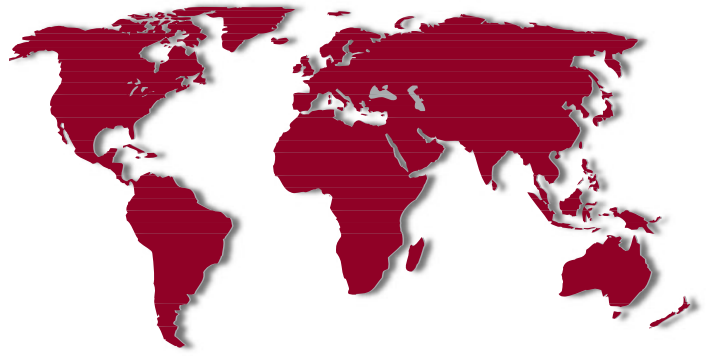

Australia	Mulgrave
Brazil	São Paulo
China	Hong Kong
	Shanghai
Denmark	Copenhagen
England	Tewkesbury
Finland	Espoo
France	Rungis



Germany	Böblingen
India	Bangalore
Ireland	Ringaskiddy
Italy	Brescia
	Malnate
Japan	Hiratsuka
Korea	Seoul
Luxembourg	Luxembourg City
Philippines	Baguio
Singapore	Singapore
Spain	Orio
Sweden	Askim
USA	East Aurora

MOOG
Industrial Controls Division
Moog Inc., East Aurora, NY 14052-0018
Telephone: +1-716-652-2000
Fax: +1-716-687-7910
Toll Free: +1-800-272-MOOG
www.moog.com/industrial
©2007 Moog Inc. All changes are reserved.